



Athena-A-V1.x-2ET
(2 stages counter-rotating)

Athena A

ELECTRIC VTOL TURBO-FAN

TURBINE ELECTRIQUE DE POUSSÉE STATIQUE

ELEKTRO-TURBO FAN

TECHNICAL SPECIFICATIONS – DATA SHEET

FEB. 2019

The European Sustainable Propulsion (ESP) Athena Series are Electric Turbofans (ETFs) engineered for efficient Vertical Take-Off and Landing (VTOL).

These devices are known by various names worldwide: *Stand Schub optimierter elektroimpeller* or *Elektro-turbo-fan* in Germany, “*Turbine électrique de poussée statique*” in France and *Electric VTOL Turbo-Fan* (ETF) or static thrust Electric Ducted Fan (EDF) in the UK and USA.

ESP Athena Series turbines are the result of several years of R&D and provide high performance and remarkable efficiency. In particular they are designed for static thrust and are optimised for VTOL and STOL operations.

Key features:

Safety is intrinsic in the design of all ESP ETFs, and there are no un-caged propellers:

- Internal redundancy with 2 separate stages, 2 motors, and 2 ESCs (2ET-version)
- Reduced size
- High thrust density
- Greater efficiency (high power loading as measured in kg/kW)

Athena A (autonomous) is offered in several variants:

- 2ET: 2 stages counter-rotating (CW or CCW)*

(*) The residual torque of counter-rotating ETF can be selected as the rotation of the first stage. To be mentioned at purchase. By default we deliver 2 stages (2ET) as residual CW.

Athena Series turbines are delivered fully assembled with Electronic Speed Controllers (ESC), motors and propellers.

Applications:

Typical usage for manned or unmanned aircraft:

- Bespoke applications for medium sized UAS/UAV
- Bespoke heavy-payload, high-safety UAV/UAA
- Extreme sports (paraglider, base-jump, turbo-ski, etc...)
- Security and Defence applications
- Electric aviation: high -efficiency VTOL and slow speed linear flight
- Airships: high efficiency thrust for VTOL & slow speed linear flight



EUROPEAN SUSTAINABLE PROPULSION





ATHENA-A-2ET-V1.64 (2 stages Contra-rotating)	
Max Diameter of Turbine at Inlet	250 mm
Rotor Assembly Diameter	195 mm
Length of Shroud	170 mmm
Weight of Turbine	1.1 kg
Max Thrust	4.0 kgf
Electrical Power at Max Thrust	1.2 kW
Normal Operating Thrust	2.9 Kgf
Power at Normal Operating Thrust	0.8 kW
Supply Voltage	22.4 V (6S)
Max Current	55 A
	0.92 Kgf @ 6.07 gf/We
Efficiency (Gross Power Loading)	1.38 Kgf @ 5.18 gf/We
at various Thrust settings	2.04 Kgf @ 4.32 gf/We
	2.76 Kgf @ 3.85 gf/We
	3.39 Kgf @ 3.33 gf/We
Material	Composite
Noise Level (@3m) Outdoor	84db at full power
Noise Level (@3m) Indoor	92dB at full power

Measurements on Athena-A-2ET-V1.6x Feb. 2018.

Notes:

The residual torque of counter-rotating ETF can be selected as the rotation of the first stage. To be mentioned at purchase. By default we deliver 2 stages (2ET) as first stage CW with residual CW. Residual torque approx.:

1.5x and 1.6x are in different composite materials and so have different density and weight ratio.

1.5x shroud: carbon composite, and other components: plastic composite.

1.6x all parts are plastic composite.

V1.5x and V1.6x include the ESC weight (ESC integrated within the turbine)

Temperatures :

Operating temperatures: non-icing conditions only & avoid direct sunlight when not flying from -10 Degree Celsius to +50 Degree Celsius for Carbon shroud (1.5x)

from 0 Degree Celsius to +40 Degree Celsius for Plastic Composite shroud(1.6x)

Storage Temp: from 5 DegC to +35 DegC – no direct sunlight- dry storage



EUROPEAN SUSTAINABLE PROPULSION

ATHENA-A ELECTRIC VTOL TURBO-FAN

Made in Europe



Notes on Technical Specifications:

Units used:

International System of Units (SI Metric): kg= kilogram, g=gram, kgf=kilogram force means thrust measured in kilograms; g/We (or gf/W) means efficiency in gram-force-thrust per Watt electric consumed.

Weight & Control Systems:

ESC means Electronic Speed Controller

The weight of our turbofans includes shroud, motors, propellers, and motor holder(s) but not the ESCs.

ESCs are delivered by ESP together with the turbofans.

Motors:

Depending on your applications we mount 2 types of electric motor with different power, please contact us for motor specifications.

Accuracies:

All figures are given with a +/- 5% accuracy.

All thrusts in gf or in kgf and efficiencies (power loadings) in gf/We or kgf/We represent gross values and are given with reference to the International Standard Atmosphere for dry air (ICAO 1964) and as such pertain to measurements at 15 degrees Celsius at 1013.25hPa and zero humidity.

Updates:

Specifications are subject to be updated without notice.

Please contact us to obtain the latest specifications.

Warranty Warning:

Any modification made to the ESC, motor, propellers, fan or shroud geometry, or over-clocking will void the warranty.

Icing condition: De-icing may not be fitted, and our electric turbofans are currently not acceptable for icing conditions.

Flight Level: Operational flight level up to 3281 ft (Feet) / 1000 M (Meter)

Restrictions: ESP authorize and warrant the use of its electric turbofans only for civilian applications up to 25kg MTOW aircraft (LT25) and lower than 3000 ft.

Shroud Warranty – outside of wearable parts:

Carbon shroud 3 years or 6 000 hrs

Plastic composite shroud 1 years or 2 500 hrs

Turbine Ingress Protection Code (IP): IP 53

About Certifications & Flight Rules:

We make no warranties on the acceptability by the local regulator nor certification under local UAV/UAS regulation or Manned aircraft regulations. It is the full responsibility of the UAS/UAV integrator, aircraft manufacturer, to liaise with its certification body if/when need be.

Unmanned:

Our turbofans may be used for VLOS & RLOS up to 25Kg MTOW depending on your region and local laws; and may not be suitable for BLOS according to your local rules. Applications with a MTOW higher than 25kg and/or above 3000ft are at your own risks. To obtain warranty above MTOW 25Kg and/or 3000 ft, you need to contact us.

Manned:

Our turbofans have to be certified within your aircraft under ULM or Prototype certification rules with your aircraft and may be suitable for VFR certification. If you embed our electric turbofan in a manned aircraft you need to contact us to have an extension of warranty.

All information in this specification sheet is proprietary.

All images are non—contractual.

Patents (EU, USA, and INTL) granted and/or pending:

EU DM/089417, 2016-5567, US Application No. 35/5000,663

Copyright © 2015, 2016, 2017, 2018 – ESP Ltd.

Contact:

contact@eu-sp.fr

ESP SAS
Angers Loire Airport
49140 Marcé
France



Contact: contact@eu-sp.fr

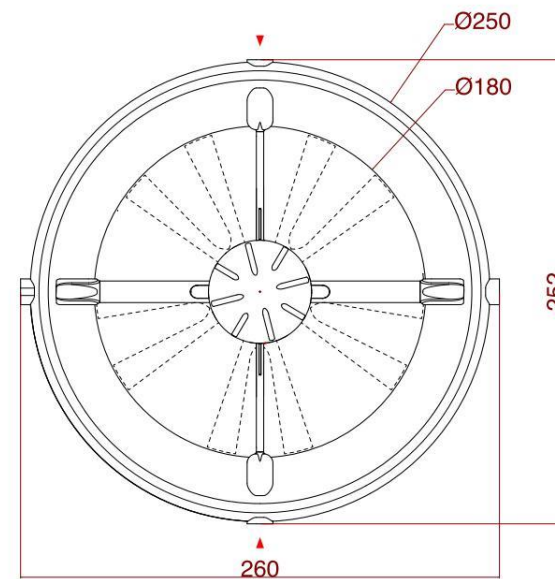
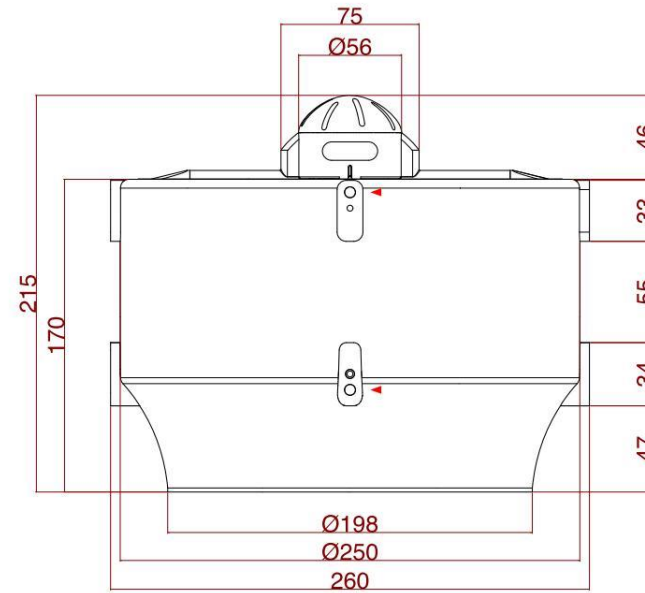
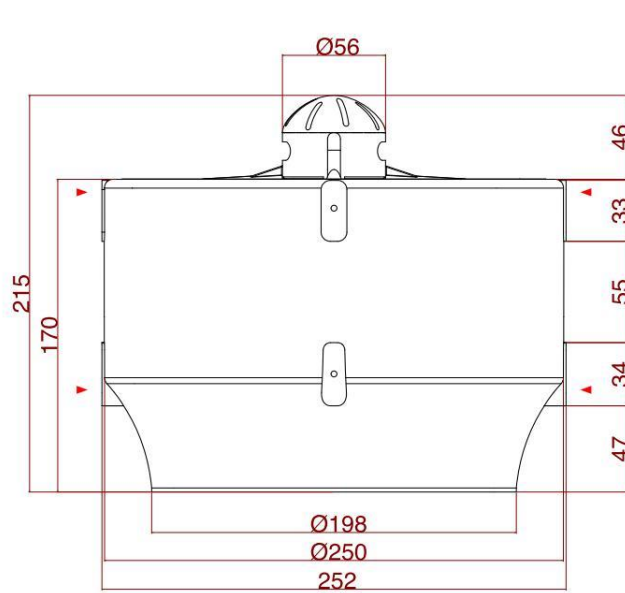

External Dimensions: Athena -A-2ET-V1.6x

Copyright © 2017, 2018, 2019 – Neva Aerospace Ltd. / ESP SAS



 EUROPEAN SUSTAINABLE PROPULSION			
scale 1:3		unit : mm	August, 19th 2017
<h2>Athena-A-2ET-V1.60</h2>			

Technical Annex – Athena-A-2ET-V1.6x

Efficiency Thrust vs Power – Athena-A-2ET-1.64 (6S)

Watt elec.	Newton	N/Kwe	Kgf	Kgf/kWe	Lbf	Lbf/kWe
200	11,31	56,55	1,15	5,77	2,54	12,71
300	15,00	50,00	1,53	5,10	3,37	11,24
400	18,29	45,73	1,87	4,66	4,11	10,28
500	20,92	41,84	2,13	4,27	4,70	9,41
600	24,47	40,78	2,50	4,16	5,50	9,17
700	26,71	38,16	2,72	3,89	6,00	8,58
800	28,68	35,85	2,92	3,66	6,45	8,06
900	31,58	35,09	3,22	3,58	7,10	7,89
1020	33,29	32,64	3,39	3,33	7,48	7,34
1118	36,40	32,56	3,71	3,32	8,18	7,32
1230	39,98	32,50	4,08	3,31	8,99	7,31

EUROPEAN SUSTAINABLE PROPULSION

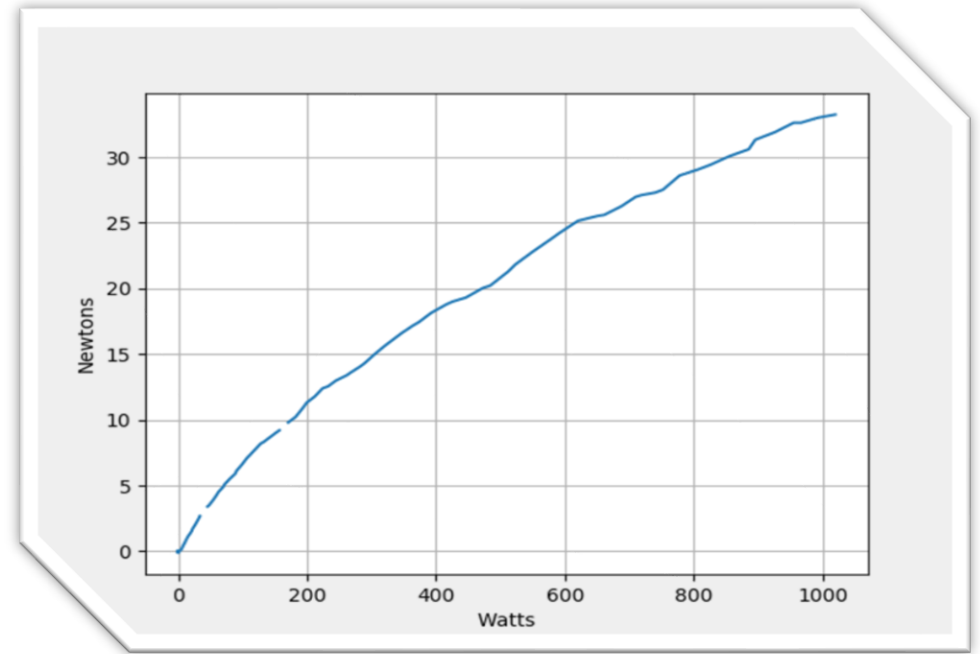

Athena-A-2ET-V1.64 - Thrust Kgf vs Watt

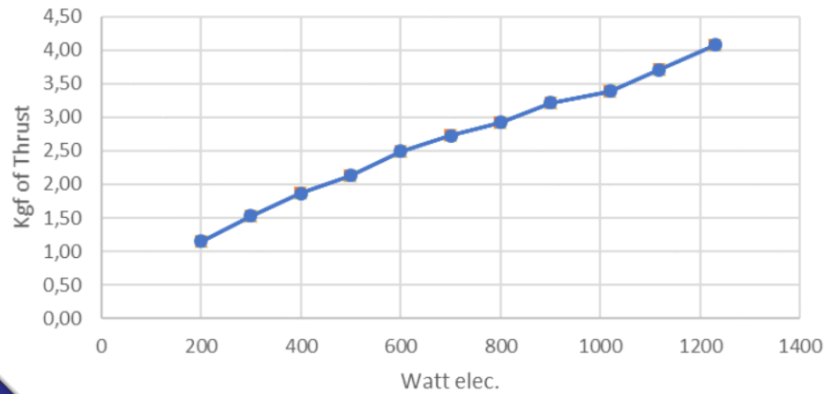

Athena-A-2ET-V1.64 - Thrust Efficiency Kgf/kWe vs Watt elec

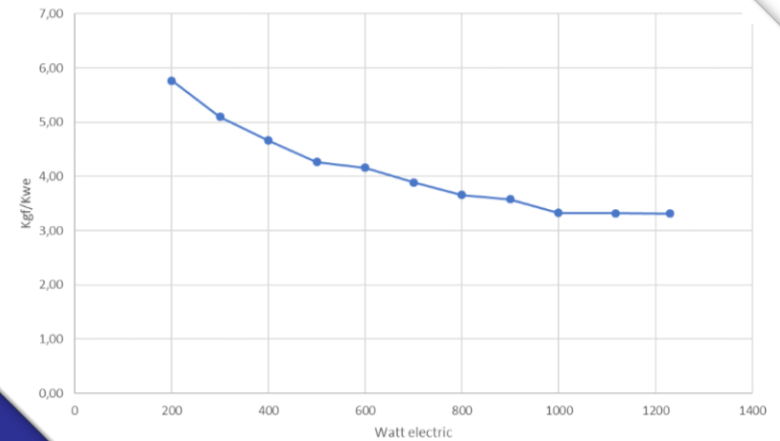



EUROPEAN SUSTAINABLE PROPULSION

www.eu-sp.fr

WORLD'S #1 MANUFACTURER OF ELECTRIC TURBOFANS

OEM TURBINES



ESP ELECTRIC TURBOFANS (ETF)

- Plug & Play
- Maintenance schedule
- Time-meter (Hobbs-meter) ESC*
- Competition grade ESC
- Highest thrust density on the market for static thrust
- Highest efficiency turbines on the market for static thrust
- Compatible with all flight controllers
- Quality controlled
- 10 Years maintenance plans

Two versions for all turbines:

- LT25 market with composite turbine body
- Aero-market with carbon composite turbine body

(*) depending on versions

AVAILABLE NOW!



Athena Series
From 2.5Kgf to 4Kgf



Hermes+ Series
From 5Kgf to 8 Kgf



Ceres Series
From 9Kgf to 15Kgf